

Thunderbird SE

Table of Contents

Introduction 2

The Motorcycle 2

Maintenance/Equipment 2

Dual Seat 3

 Removal 3

 Installation 4

Pillion Footboards 5

 Adjustment 5

Sissy Bar and Rack 6

 Removal 6

 Installation 7

Windscreen 8

 Removal 8

 Installation 8

Panniers 10

 To open: 10

 To close: 10

Changing Gears 11

Braking 11

Specifications 12

Foreword - Safety First

Introduction

This handbook supplement contains information for the Thunderbird SE model, and includes information on:

- rider and pillion foot boards;
- dual seat;
- quick release sissy bar and luggage rack assembly;
- windscreen;
- leather panniers;
- specifications.

The supplement must be read in conjunction with the accompanying owner's handbook.

All other details are as described in the accompanying owner's handbook.

Always keep this supplement with the owner's handbook, store them with the motorcycle and refer to them whenever necessary.

Foreword - Safety First

The Motorcycle

Warning

This motorcycle is designed for use as a two-wheeled vehicle capable of carrying a rider on his/her own, or a rider and one passenger.

The total weight of the rider, and any passenger, accessories and luggage must not exceed the maximum load limit of 205 kg (452 lbs).

Maintenance/Equipment

Warning

When banking and the bank angle indicator, attached to the rider's footboard, makes contact with the ground, the motorcycle is nearing its bank angle limit. A further increase of the banking angle is unsafe.

Banking to an unsafe angle may cause instability, loss of motorcycle control and an accident.

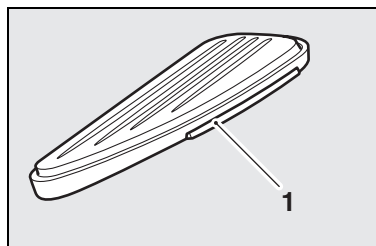

1. Bank angle indicator

General Information

General Information

Dual Seat

Removal

1. Remove the rear fixing using the Allen key provided in the tool kit.

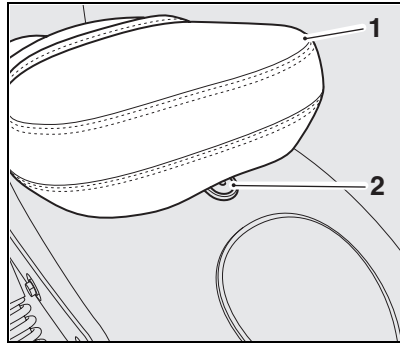

1. Seat
2. Fixing

2. Remove the two side fixings using the Allen key provided in the tool kit.

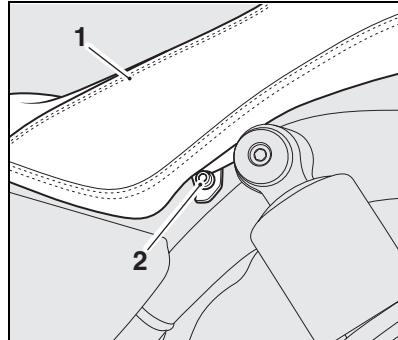

1. Seat
2. Side fixing (left hand shown)
3. Lift the seat up at the rear for complete removal from the motorcycle.

General Information

Installation

1. Engage the seat's tongue under the fuel tank and align the side fixings with the frame fixing points. Fit the side fixings, but do not fully tighten at this stage.

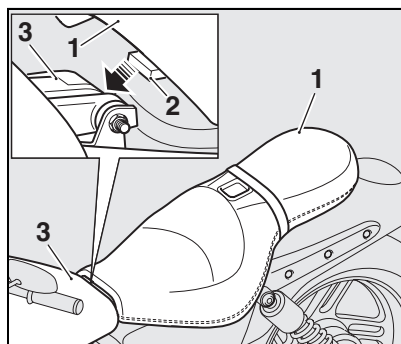

1. Seat
2. Seat tongue
3. Fuel tank

2. Align the seat rear fixing bracket with the fixing position on the rear mudguard. Fit the original fixing and tighten to **10 Nm**.

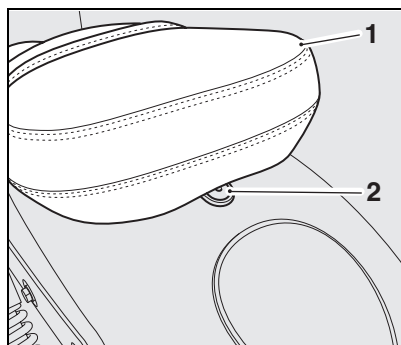

1. Seat
2. Fixing

3. Tighten the side fixings to **9 Nm**.

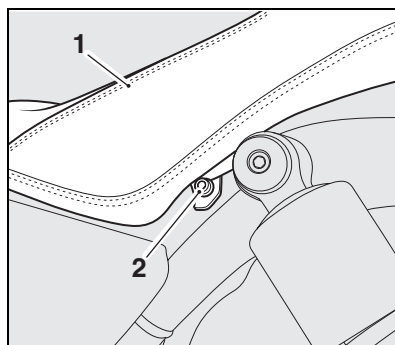

1. Seat
2. Side fixing (left hand shown)

General Information

Pillion Footboards

Adjustment

The position of the pillion footboards can be adjusted. To adjust their position, carry out the following:

Note:

- **To prevent damage to other components, support the footboard when loosening the adjustable arm and clevis bolts.**

1. Loosen the bolts for the adjustable arm and the adjustable clevis.

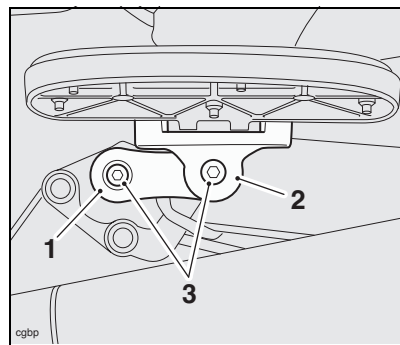

1. Adjustable arm
2. Adjustable clevis
3. Bolts

2. Adjustment of the adjustable arm is possible to the limits shown below.

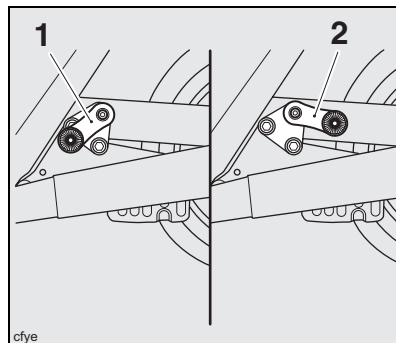

1. Adjustable arm forward position
2. Adjustable arm rearward position
3. Move the footboard to the pillion's preferred position and tighten the bolts to **27 Nm**. Ensure there is a minimum clearance of 15 mm between the footboard and the exhaust silencer.
4. Repeat the adjustment procedure for the remaining footboard.

General Information

Sissy Bar and Rack

Removal

1. Remove the seat as described on page 3.
2. Insert the key in to the sissy bar lock (located behind the left hand sissy bar bracket) and turn anti-clockwise to unlock.

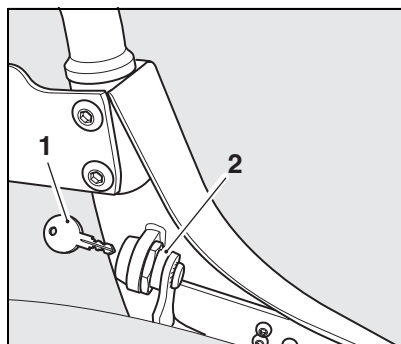

1. Key
2. Lock

3. With the key operated lock in the unlocked position, pull both latch levers rear-wards and simultaneously lift the rear of the sissy bar off the rear mountings.

4. Lift the sissy bar off the front mountings for complete removal from the motorcycle.

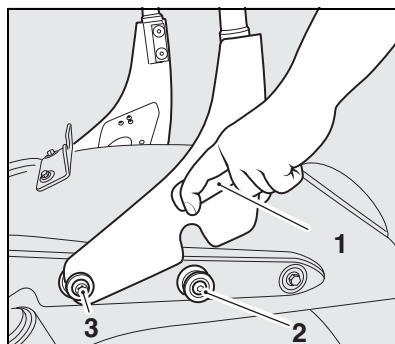

1. Latch lever, left hand side shown
2. Rear mounting
3. Front mounting

General Information

Installation

1. Position the sissy bars to the front mountings.

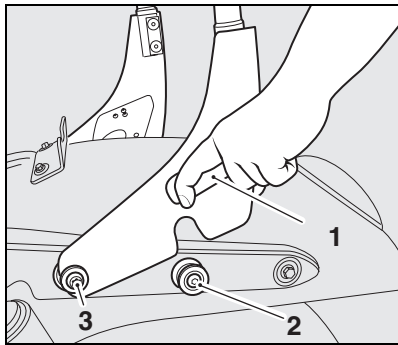

- 1. Latch lever, left hand side shown**
- 2. Rear mounting**
- 3. Front mounting**

2. Pull the latch levers on the mounting plates fully rear-wards and engage the rear slots onto the rear mountings. Release the latch levers and apply downward pressure until the mounting plates lock in to the rear mountings.

Warning

To prevent detachment of the sissy bar and rack during riding, after fitting always grasp the rack and pull firmly upwards. If the sissy bar and rack is not correctly secured in the lock, it will detach from the lock. A loose or detached sissy bar and rack could cause loss of motorcycle control and an accident.

3. Slide the latch levers forward in to the locked position.
4. Insert the key and turn clockwise to the locked position.
5. Refit the seat, as described on page 4.

General Information

Windscreen

Removal

Warning

Throughout this operation, ensure that the motorcycle is stabilised and adequately supported to prevent risk of injury from the motorcycle falling.

To remove the windscreen, carry out the following procedure.

1. Turn the windscreen lock to the unlocked position.
2. Stand astride the front wheel and firmly grip both sides of the windscreen close to the top.

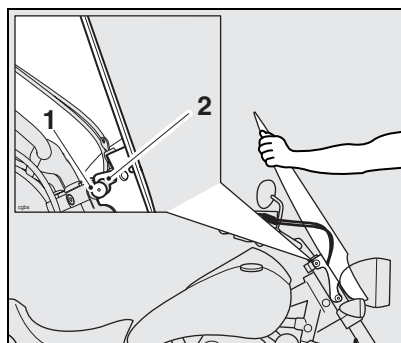

1. Upper mounting
2. Windscreen upper mounting slot

3. Pull the windscreen firmly to disengage the upper mountings. Then lift the windscreen up to disengage the lower mountings and completely remove from the motorcycle.

Installation

Warning

Throughout this operation, ensure that the motorcycle is stabilised and adequately supported to prevent risk of injury from the motorcycle falling.

1. Turn the windscreen lock to the unlocked position and remove the key.

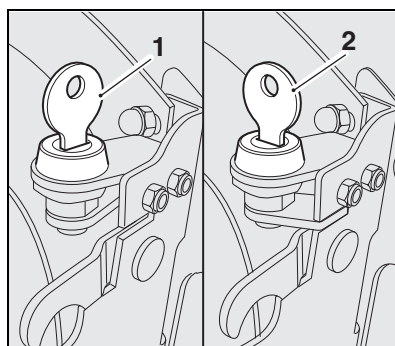

1. Unlocked position
2. Locked position

General Information

2. Stand astride the front wheel and align the windscreen lower mounting slots to the lower mountings on the mounting brackets.

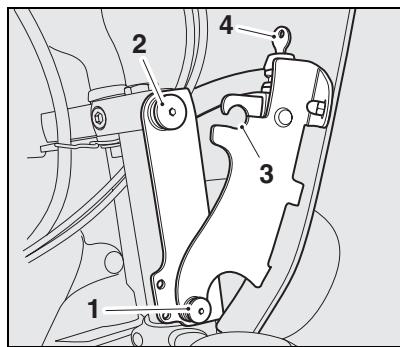

1. Lower mounting
2. Upper mounting
3. Upper mounting slot
4. Lock

Note:

- An audible click can be heard when the windscreen upper mountings are fully engaged.

3. Align the windscreen upper mounting slots to the mountings on the motorcycle. Firmly grip both sides of the windscreen close to the top, and with a firm push, fully engage the upper mountings.

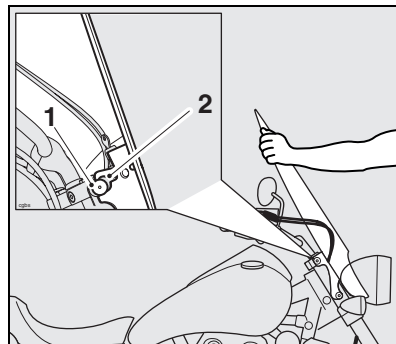

1. Upper mounting
2. Windscreen upper mounting slot

4. Turn the windscreen lock to the locked position.

Warning

Never attempt to clean or adjust the windscreen while riding the motorcycle. Removal of the rider's hands from the handlebars while riding the motorcycle will diminish the ability of the rider to maintain the control of the motorcycle. Attempting to clean or adjust the windscreen while riding the motorcycle may result in loss of control of the motorcycle and an accident.

General Information

Panniers

To open:

1. Lift the leather strap below the buckle to reveal the quick release fastener.
2. Squeeze the two tangs together to release the quick release fastener.

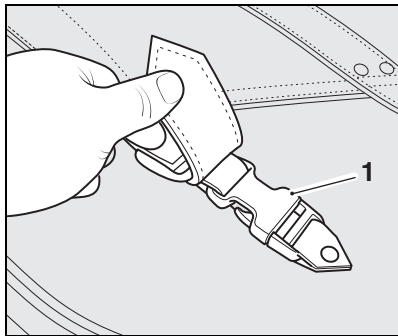

- 1. Quick release fastener**
3. Release the press studs at the front and rear of the pannier.
4. Open the pannier, releasing the hook and loop strip as you do so.

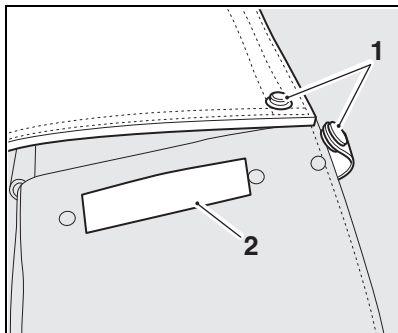

- 1. Press stud**
- 2. Hook and loop strip**

To close:

1. Close the pannier lid, securing the hook and loop strip as you do so, and secure the two press studs at the front and rear.
2. Secure the two quick release fasteners.
3. An audible click will be heard when the quick release fastener is correctly closed.

Warning

The maximum safe load for each pannier is 5 kg (11 lbs). Never exceed this loading limit as this may cause the motorcycle to become unstable leading to loss of control and an accident.

Warning

In all cases, loads must be evenly distributed on both sides of the motorcycle. Uneven loading may cause instability, loss of control and an accident.

How to Ride The Motorcycle

How to Ride The Motorcycle

Changing Gears

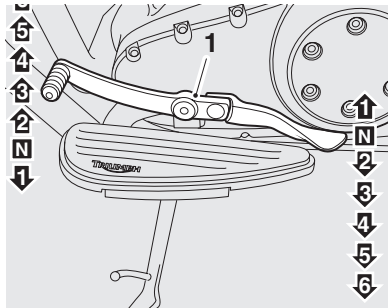

1. Gear Change Lever

Braking

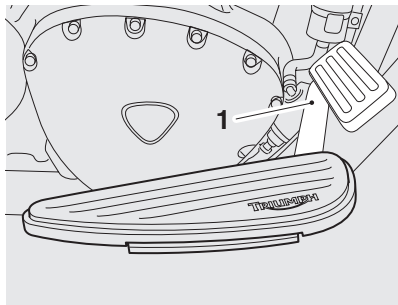

1. Rear brake pedal

Accessories and Loading

Warning

Incorrect loading may result in an unsafe riding condition leading to an accident.

Always ensure any loads carried are evenly distributed on both sides of the motorcycle. Ensure that the load is correctly secured such that it will not move around while the motorcycle is in motion.

Always check the load security regularly (though not while the motorcycle is in motion) and ensure that the load does not extend beyond the rear of the motorcycle.

Never exceed the maximum vehicle loading weight of 205 kg (451.9 lbs).

This maximum loading weight is made up from the combined weight of the rider, passenger, any accessories fitted and any load carried.

Specifications

Specifications

The specifications for the Thunderbird SE are the same as the details given in the accompanying handbook with the exception of the following listed below.

Dimensions

Overall Width	890 mm (35 in)
Overall Height.....	1460 mm (57.4 in)
Seat Height	720 mm (28.3 in)

Weights

Dry Weight	334 kg (736 lbs)
Maximum Payload	205 kg (452 lbs)